

Smart Bell Panorama 73/52

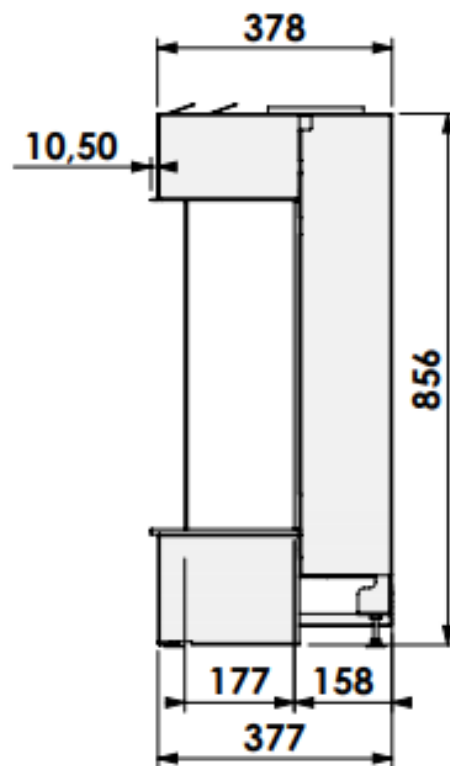

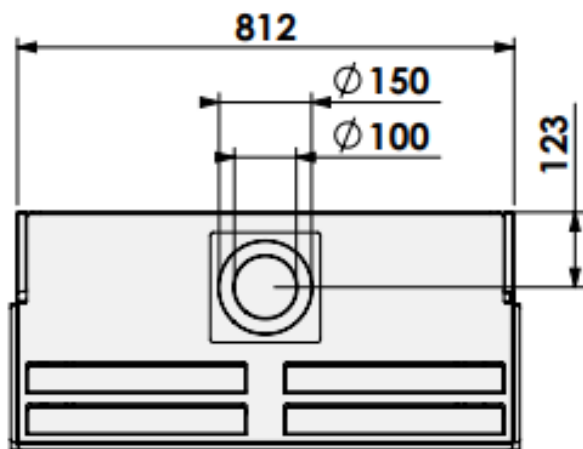

Effekt (Min-maks).....1,7- 5,6 KW
 Std. brennerMagnifire
 Vekt95 kg
 Avgass størrelse $\varnothing 150/100$ mm
 ModellSmart Bell Panorama 73/52

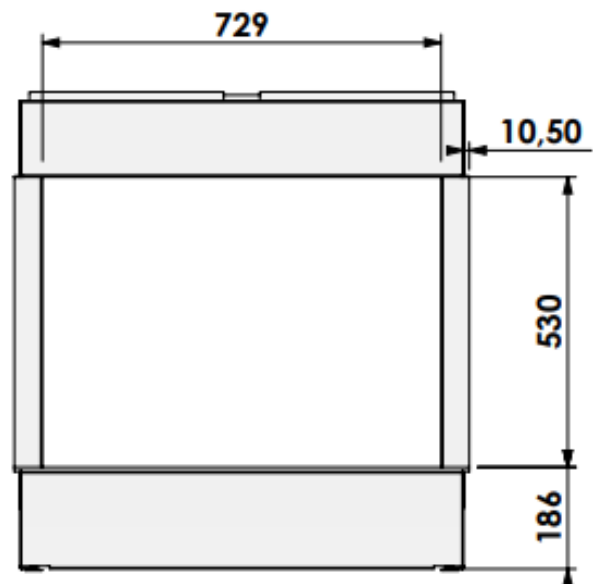